



Volba odběrových míst na termicky aktivních haldách ČR a metodika odběru vzorků plyných a prachových emisí

Michal Vaštyl



Odběrová místa

- Zmapování oblasti (terénní průzkum)
- Termosnímký – pomoci dronu
- Průzkum v terénu s termosnímký
- Screeningové odběry
- Určení odběrových míst pro vrty
- Vrty



Termosnímký odvalu Ema



PŘEKRAČUJEME HRANICE
PRZEKRACZAMY GRANICE
2014—2020



EVROPSKÁ UNIE / UNIA EUROPEJSKA
EVROPSKÝ FOND PRO REGIONÁLNÍ ROZVOJ
EUROPEJSKI FUNDUSZ ROZWOJU REGIONALNEGO

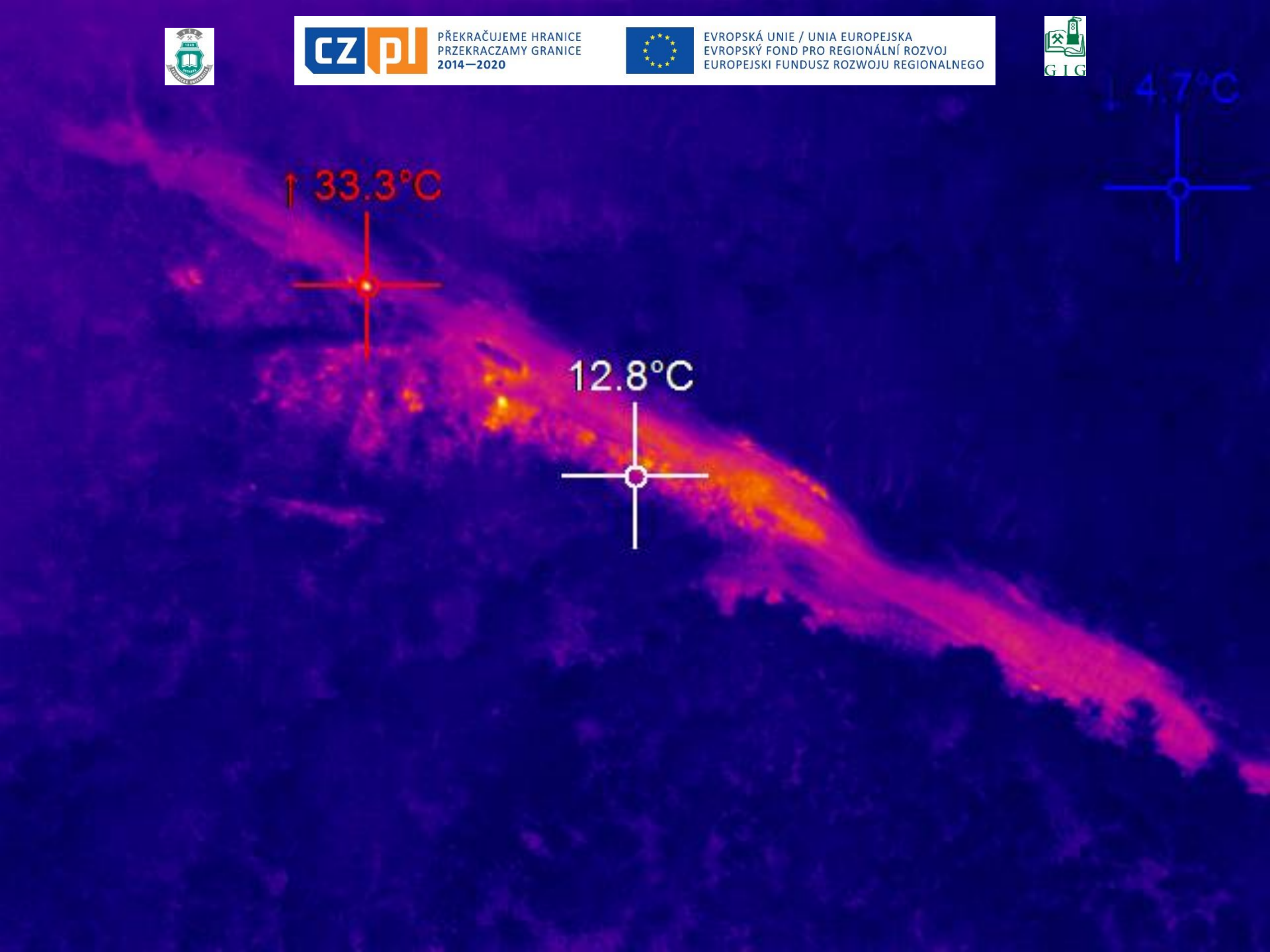



PŘEKRAČUJEME HRANICE
PRZEKRACZAMY GRANICE
2014—2020



EVROPSKÁ UNIE / UNIA EUROPEJSKA
EVROPSKÝ FOND PRO REGIONÁLNÍ ROZVOJ
EUROPEJSKI FUNDUSZ ROZWOJU REGIONALNEGO

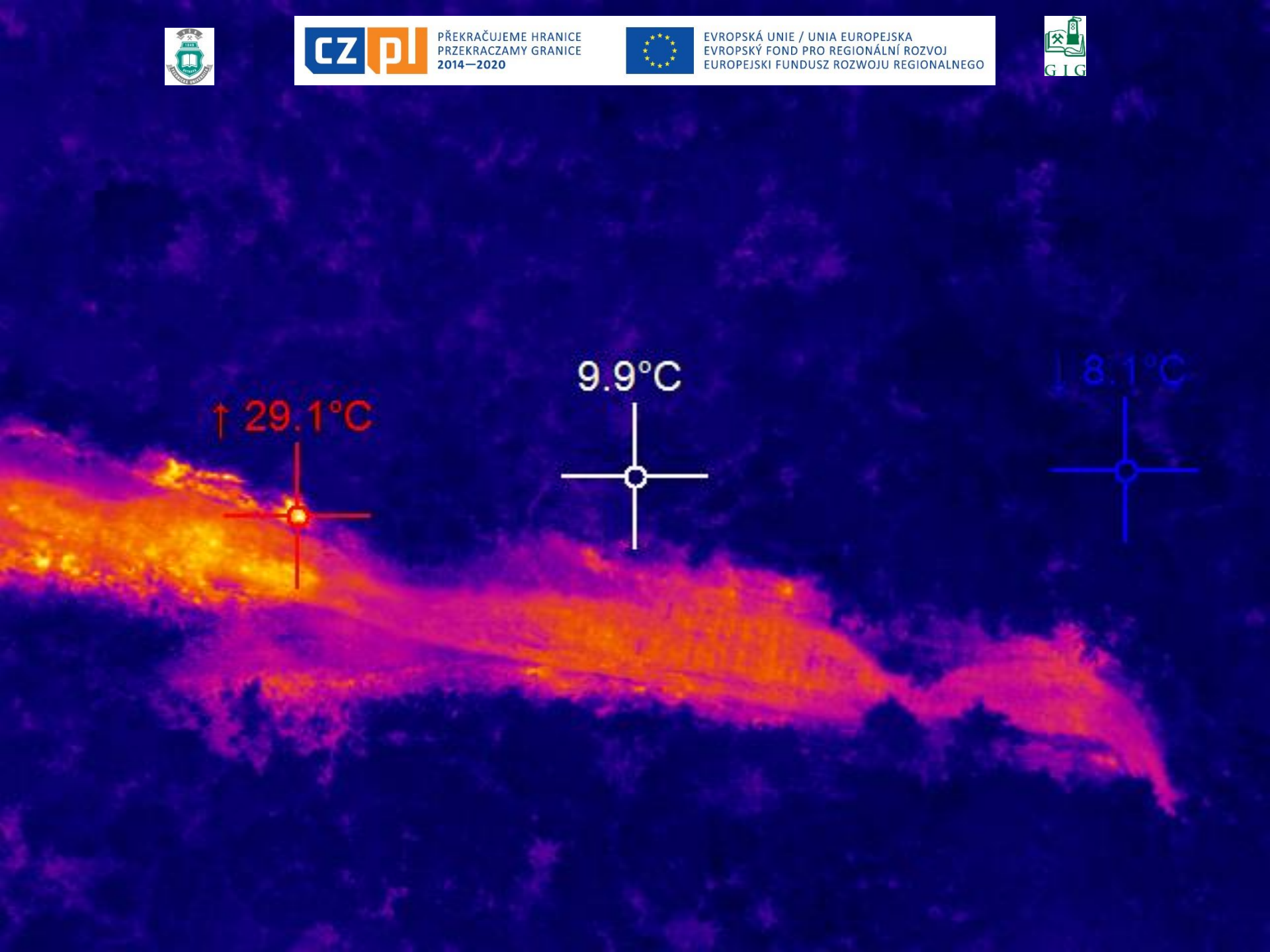



Termosnímký odvalu Hedvika



PŘEKRAČUJEME HRANICE
PRZEKRACZAMY GRANICE
2014—2020



EVROPSKÁ UNIE / UNIA EUROPEJSKA
EVROPSKÝ FOND PRO REGIONÁLNÍ ROZVOJ
EUROPEJSKI FUNDUSZ ROZWOJU REGIONALNEGO



13.4°C

21.6°C

↑ 71.6°C

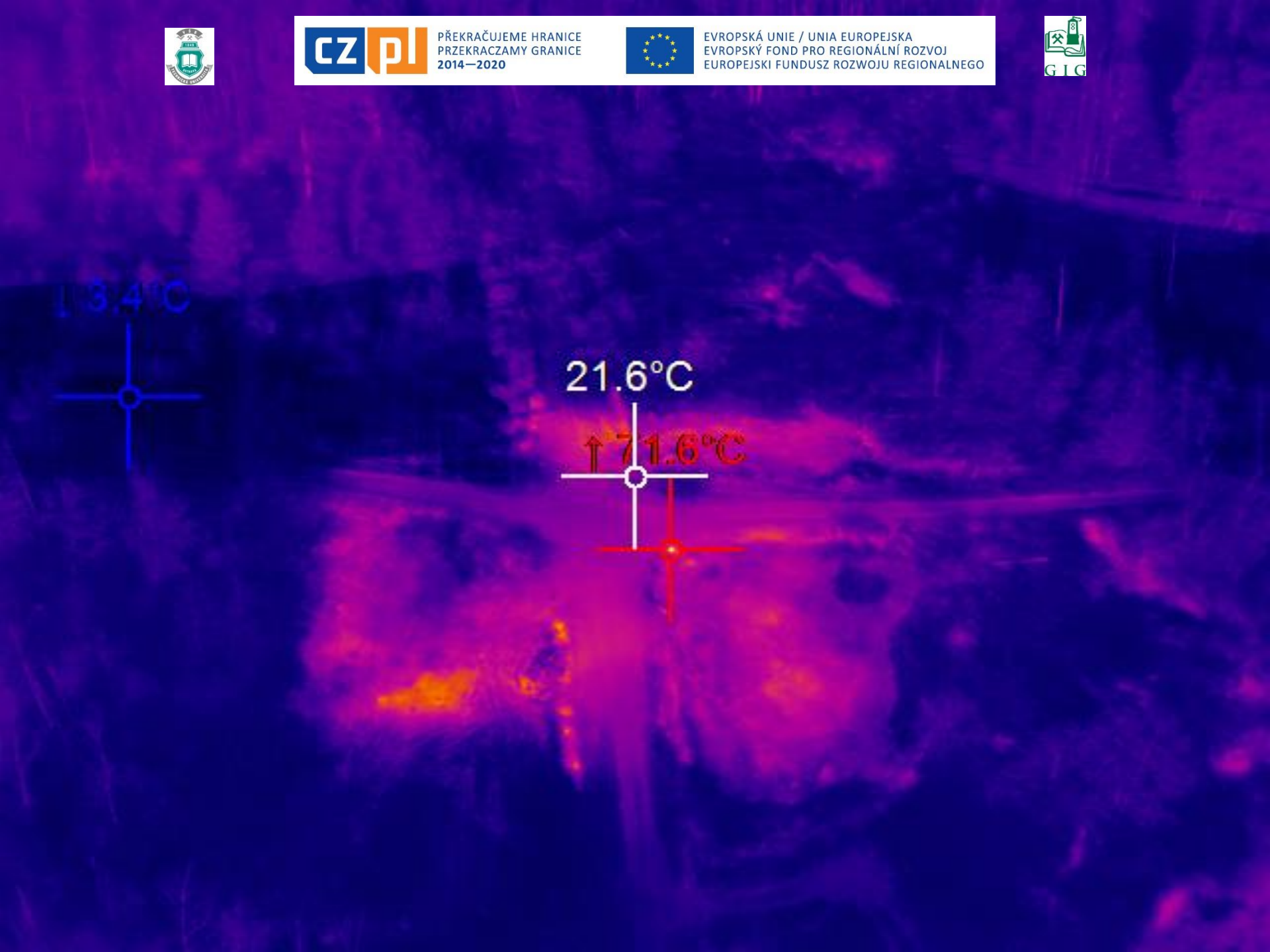



PŘEKRAČUJEME HRANICE
PRZEKRACZAMY GRANICE
2014—2020



EVROPSKÁ UNIE / UNIA EUROPEJSKA
EVROPSKÝ FOND PRO REGIONÁLNÍ ROZVOJ
EUROPEJSKI FUNDUSZ ROZWOJU REGIONALNEGO



↑ 33.9°C

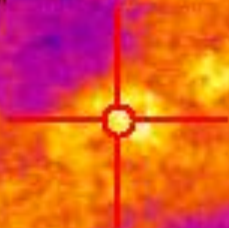

14.1°C

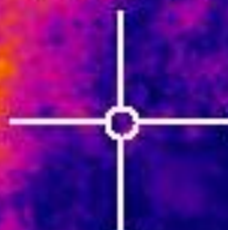

↓ -0.2°C

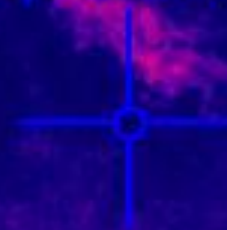



PŘEKRAČUJEME HRANICE
PRZEKRACZAMY GRANICE
2014—2020



EVROPSKÁ UNIE / UNIA EUROPEJSKA
EVROPSKÝ FOND PRO REGIONÁLNÍ ROZVOJ
EUROPEJSKI FUNDUSZ ROZWOJU REGIONALNEGO

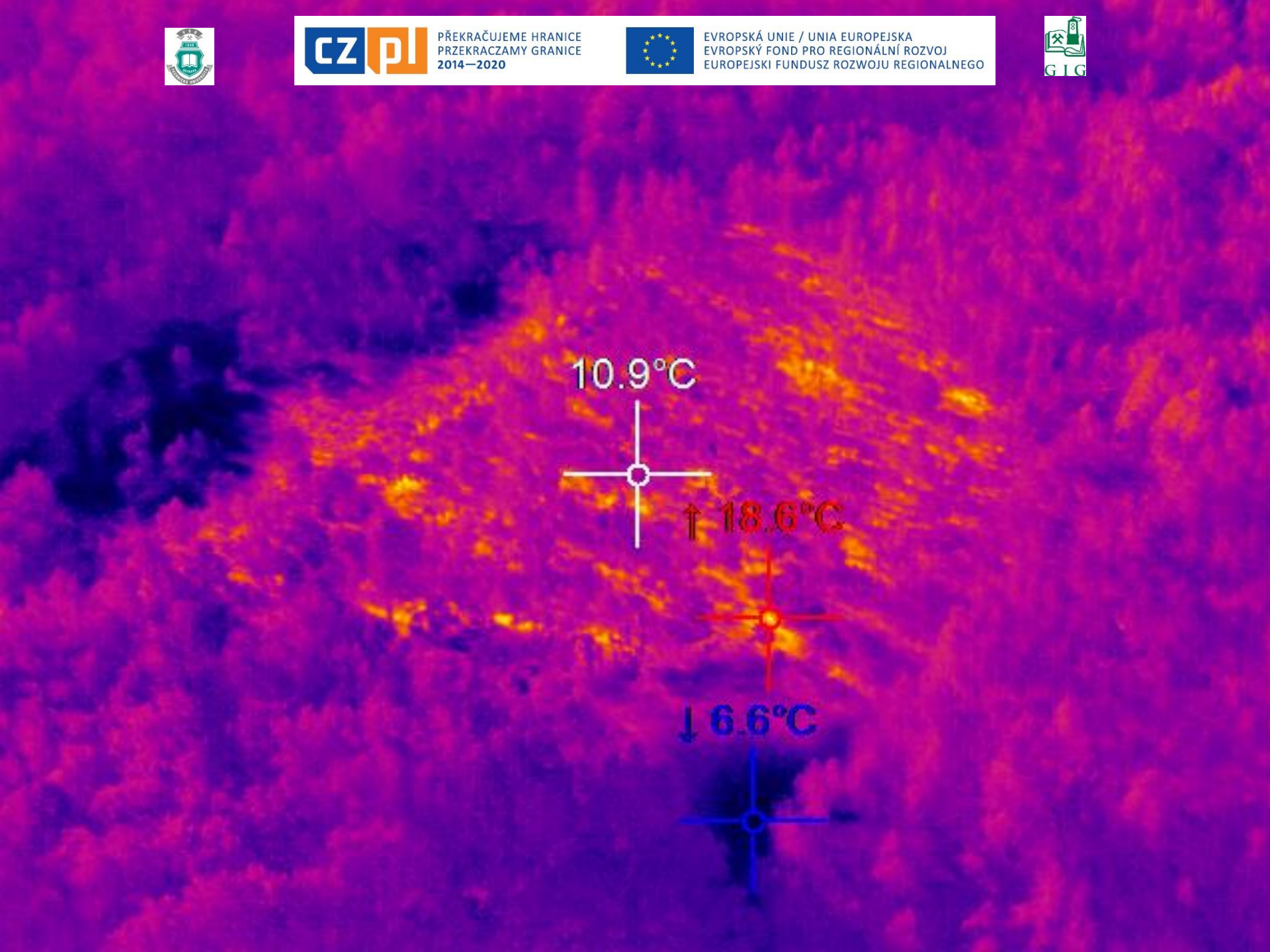



Termosnímký odvalu Heřmanice



PŘEKRAČUJEME HRANICE
PRZEKRACZAMY GRANICE
2014—2020



EVROPSKÁ UNIE / UNIA EUROPEJSKA
EVROPSKÝ FOND PRO REGIONÁLNÍ ROZVOJ
EUROPEJSKI FUNDUSZ ROZWOJU REGIONALNEGO



↓ 2.7°C

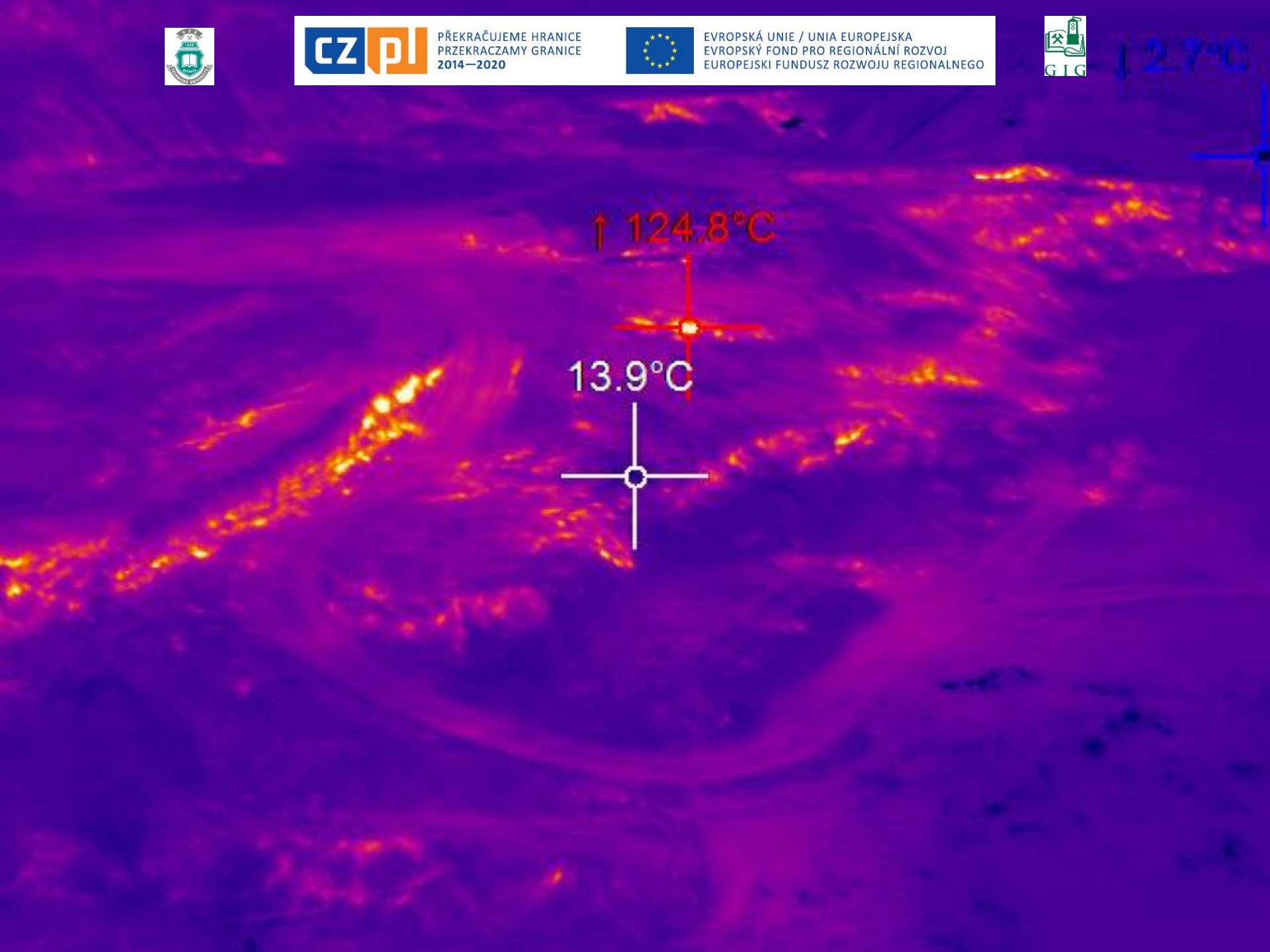



PŘEKRAČUJEME HRANICE
PRZEKRACZAMY GRANICE
2014—2020



EVROPSKÁ UNIE / UNIA EUROPEJSKA
EVROPSKÝ FOND PRO REGIONÁLNÍ ROZVOJ
EUROPEJSKI FUNDUSZ ROZWOJU REGIONALNEGO

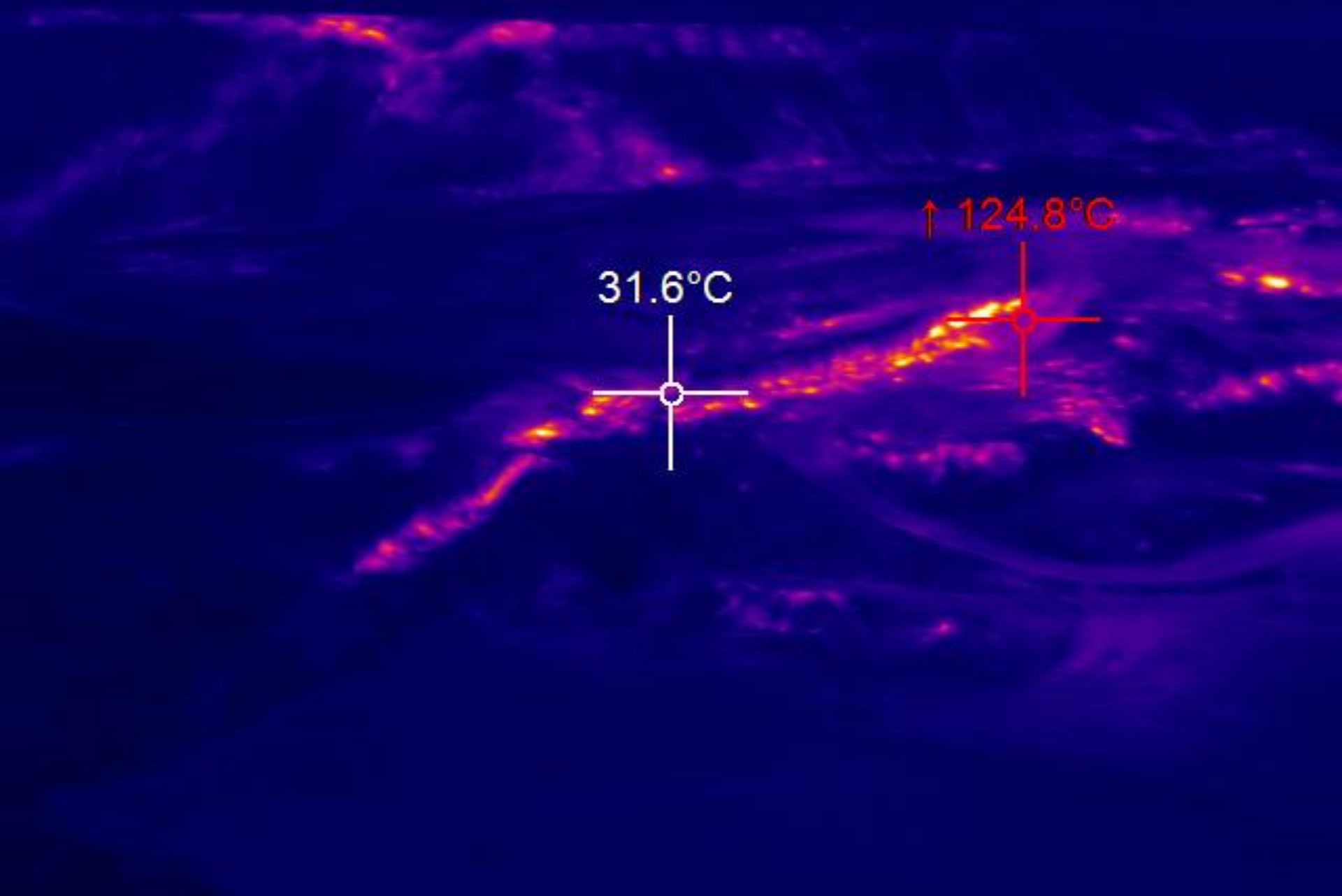



PŘEKRAČUJEME HRANICE
PRZEKRACZAMY GRANICE
2014—2020



EVROPSKÁ UNIE / UNIA EUROPEJSKA
EVROPSKÝ FOND PRO REGIONÁLNÍ ROZVOJ
EUROPEJSKI FUNDUSZ ROZWOJU REGIONALNEGO



↓ 11.7°C

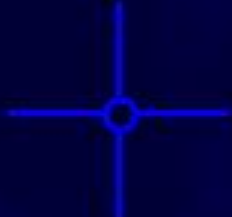

17.2°C

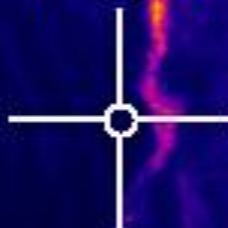



Zvolená odběrová místa



PŘEKRAČUJEME HRANICE
PRZEKRACZAMY GRANICE
2014—2020



EVROPSKÁ UNIE / UNIA EUROPEJSKA
EVROPSKÝ FOND PRO REGIONÁLNÍ ROZVOJ
EUROPEJSKI FUNDUSZ ROZWOJU REGIONALNEGO



EMA

Halda Ema



EMA1

EMA2



PŘEKRAČUJEME HRANICE
PRZEKRACZAMY GRANICE
2014—2020



EVROPSKÁ UNIE / UNIA EUROPEJSKA
EVROPSKÝ FOND PRO REGIONÁLNÍ ROZVOJ
EUROPEJSKI FUNDUSZ ROZWOJU REGIONALNEGO



HEDVIKA

The1

The2

The3

The3

The5





PŘEKRAČUJEME HRANICE
PRZEKRACZAMY GRANICE
2014—2020



EVROPSKÁ UNIE / UNIA EUROPEJSKA
EVROPSKÝ FOND PRO REGIONÁLNÍ ROZVOJ
EUROPEJSKI FUNDUSZ ROZWOJU REGIONALNEGO



HEŘMANICE



THř3

THř2

THř1

THř4

THř6

THř7

THř8

THř5

Odběrový bod

- H - hloubka vrtu
- h_p - hloubka zapaštění nerezové trubky (odběrový bod)
- h_n - výška trubky vystupující nad povrch odvalu
- h_b - výška odběrového trubice
- h_o - vzdálenost místa odběru od spoje T_s a T_m
- T_s a T_m - nerezové trubky (nerez 1.4004)

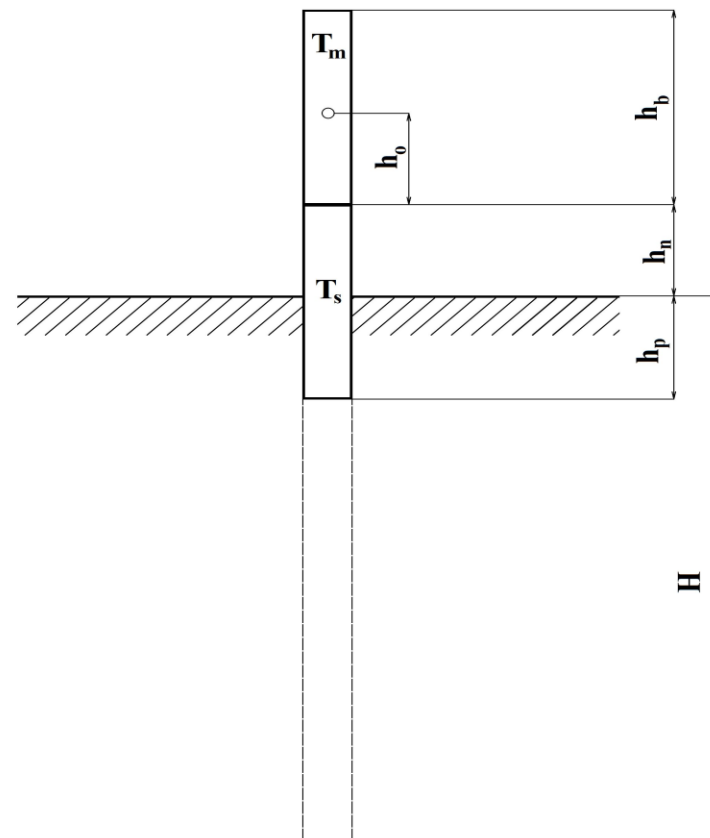



PŘEKRAČUJEME HRANICE
PRZEKRACZAMY GRANICE
2014—2020



EVROPSKÁ UNIE / UNIA EUROPEJSKA
EVROPSKÝ FOND PRO REGIONÁLNÍ ROZVOJ
EUROPEJSKI FUNDUSZ ROZWOJU REGIONALNEGO



HEDVIKA



HEŘMANICE





PŘEKRAČUJEME HRANICE
PRZEKRACZAMY GRANICE
2014—2020



EVROPSKÁ UNIE / UNIA EUROPEJSKA
EVROPSKÝ FOND PRO REGIONÁLNÍ ROZVOJ
EUROPEJSKI FUNDUSZ ROZWOJU REGIONALNEGO



G I G

Screeningová metoda odběru

- Stanovení koncentrace
 - PAHs
 - PM_x a toxické kovy

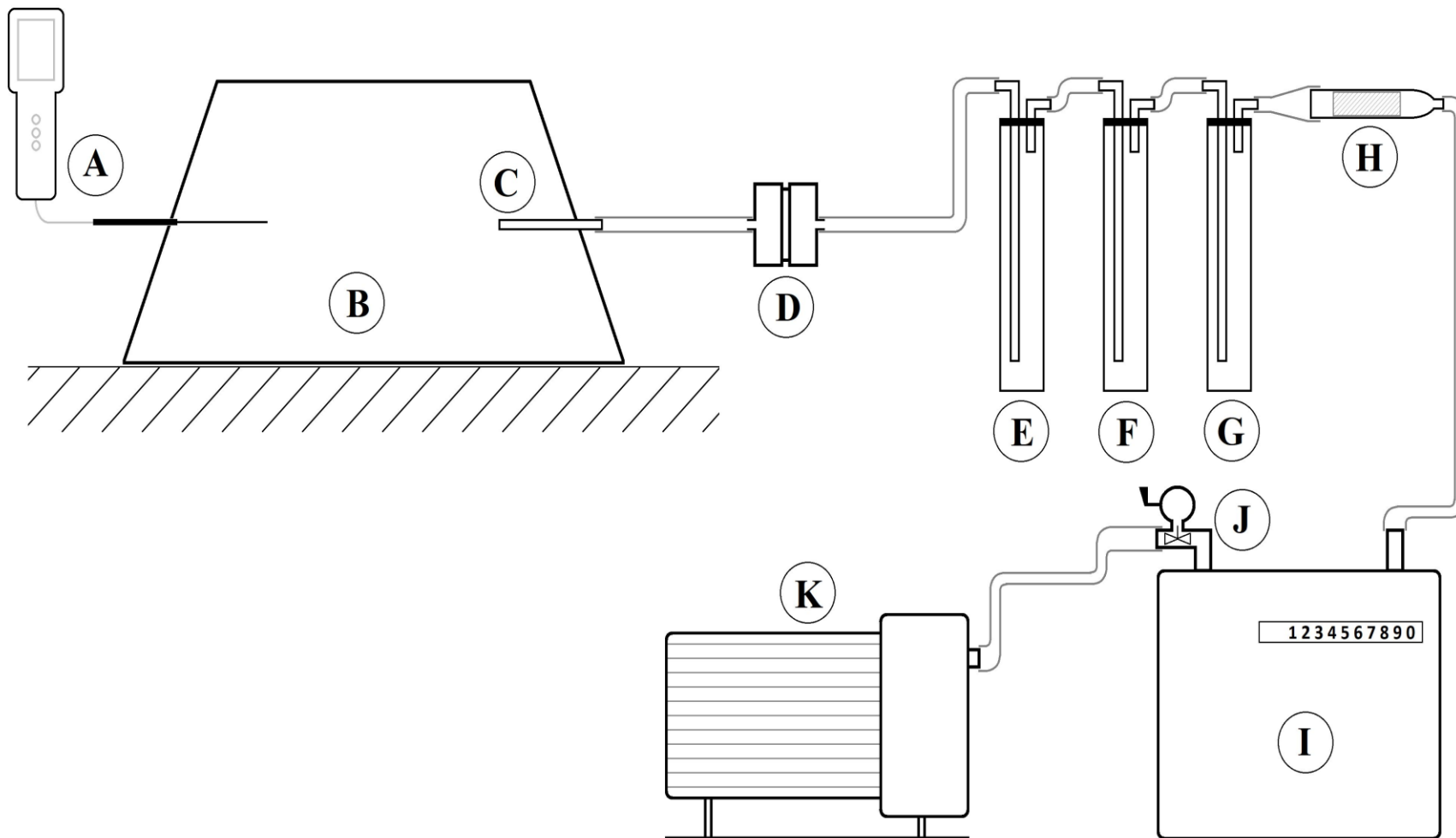

Screeningová odběrová aparatura



Odběrová aparatura

- Přesné odběry
- Úprava aparatury dle:
 - Teplota
 - Rychlost proudění
 - Kondenzace

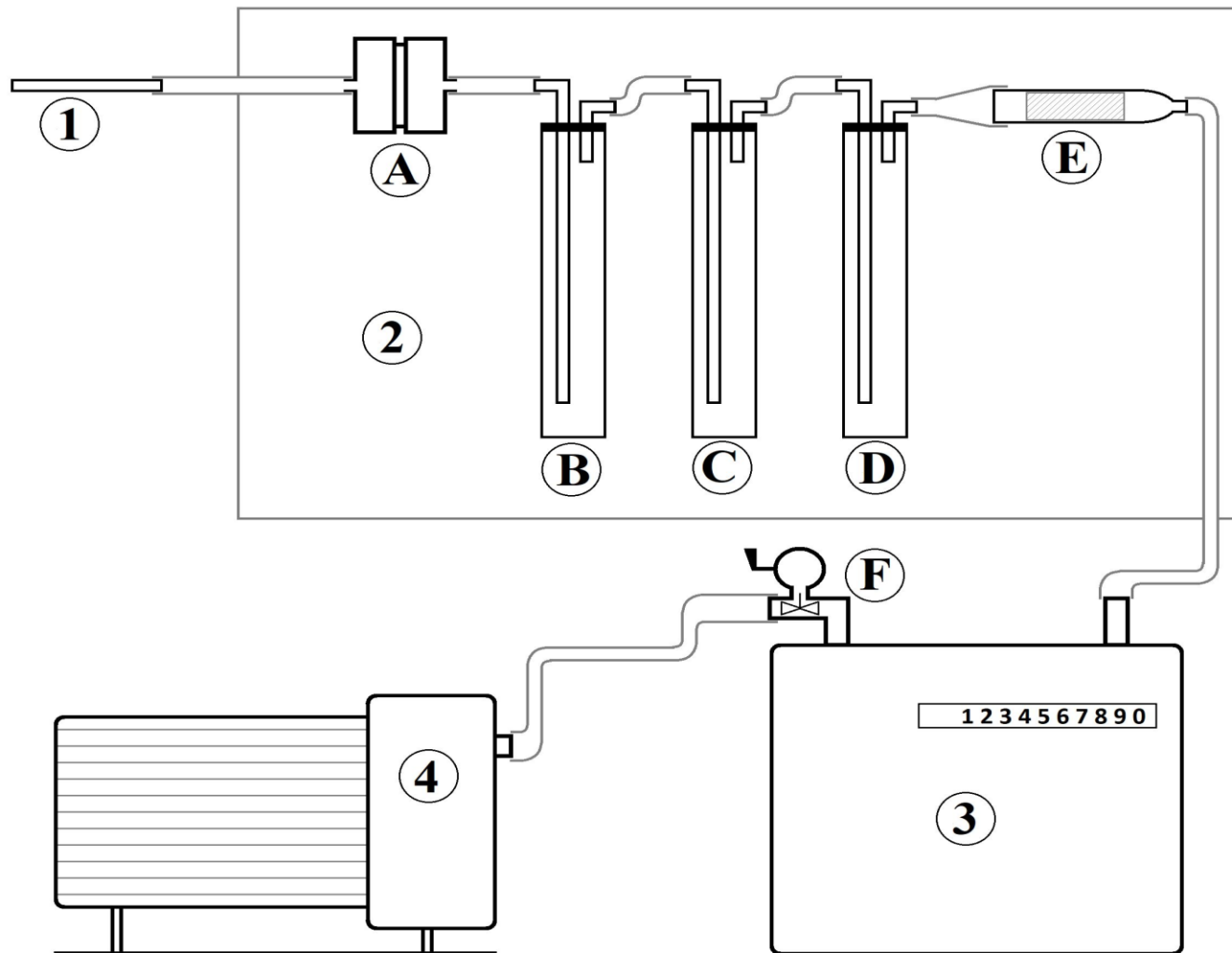

Základní odběrová aparatura

Teplota max: 180 °C
Rychlost proudění: 5-10 dm³ min⁻¹

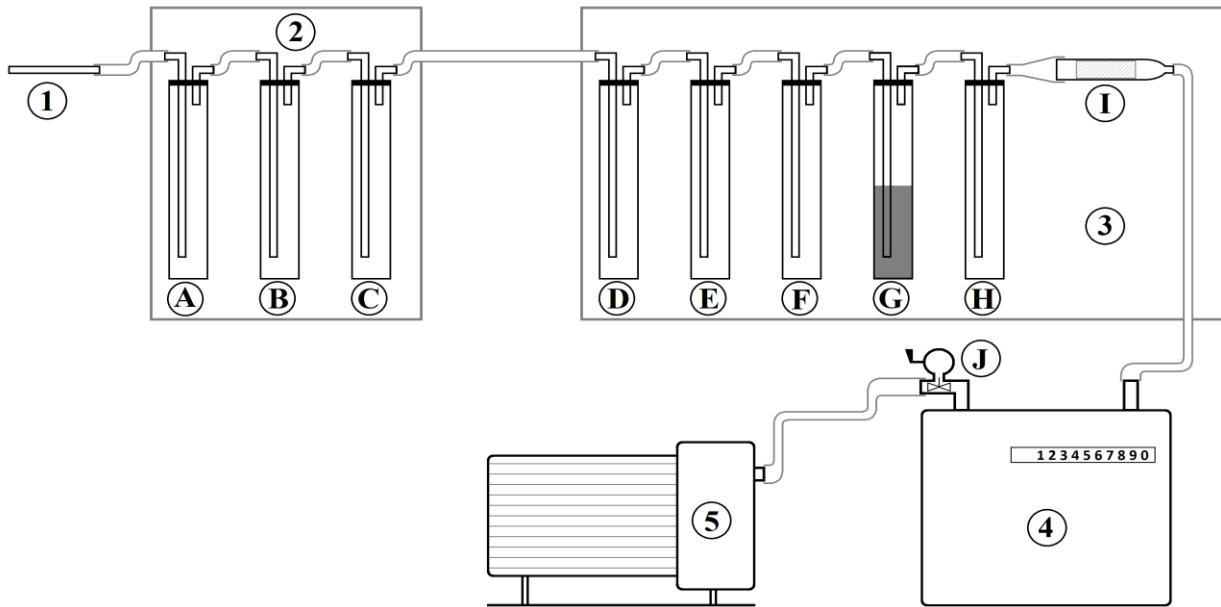

Teplota max: 300 °C
 Rychlost proudění: 10-15 dm³ min⁻¹

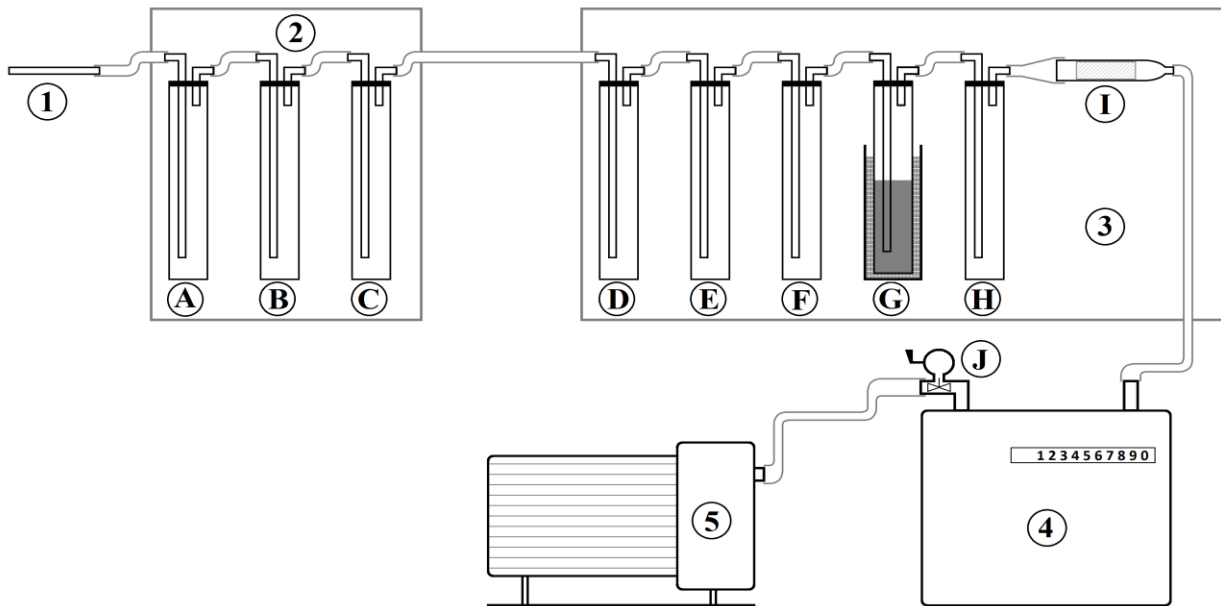

Teplota max: 350 °C
 Rychlost proudění: 5-45 dm³ min⁻¹



PŘEKRAČUJEME HRANICE
 PRZEKRACZAMY GRANICE
 2014–2020



EVROPSKÁ UNIE / UNIA EUROPEJSKA
 EVROPSKÝ FOND PRO REGIONÁLNÍ ROZVOJ
 EUROPEJSKI FUNDUSZ ROZWOJU REGIONALNEGO

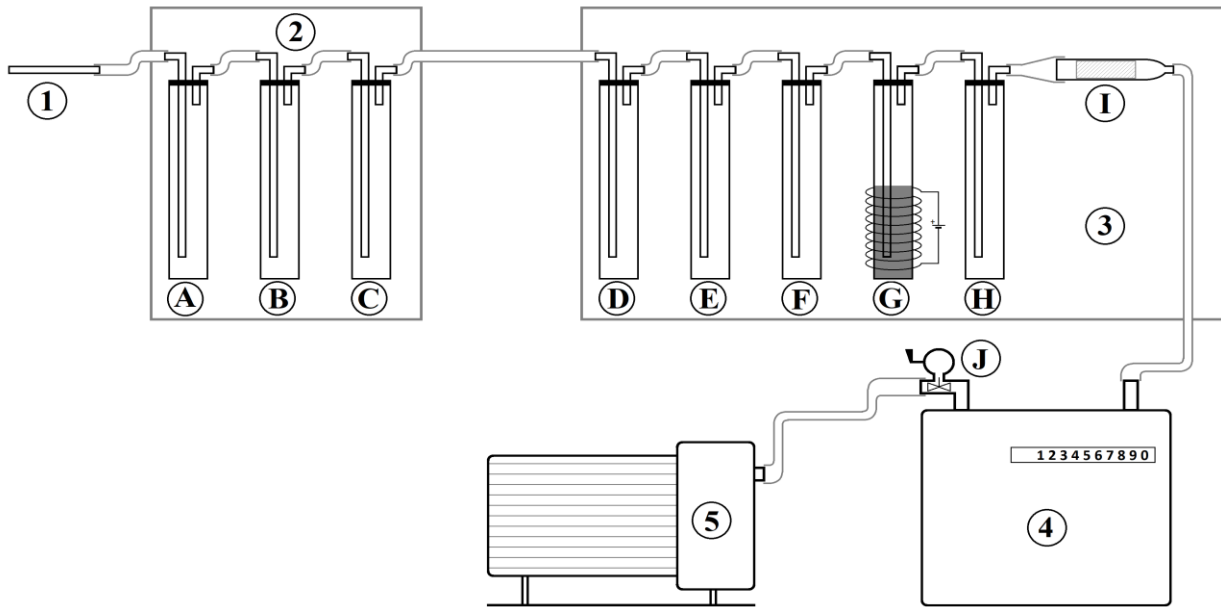

Teplota max: 400 °C
 Rychlost proudění: 1-50 dm³ min⁻¹

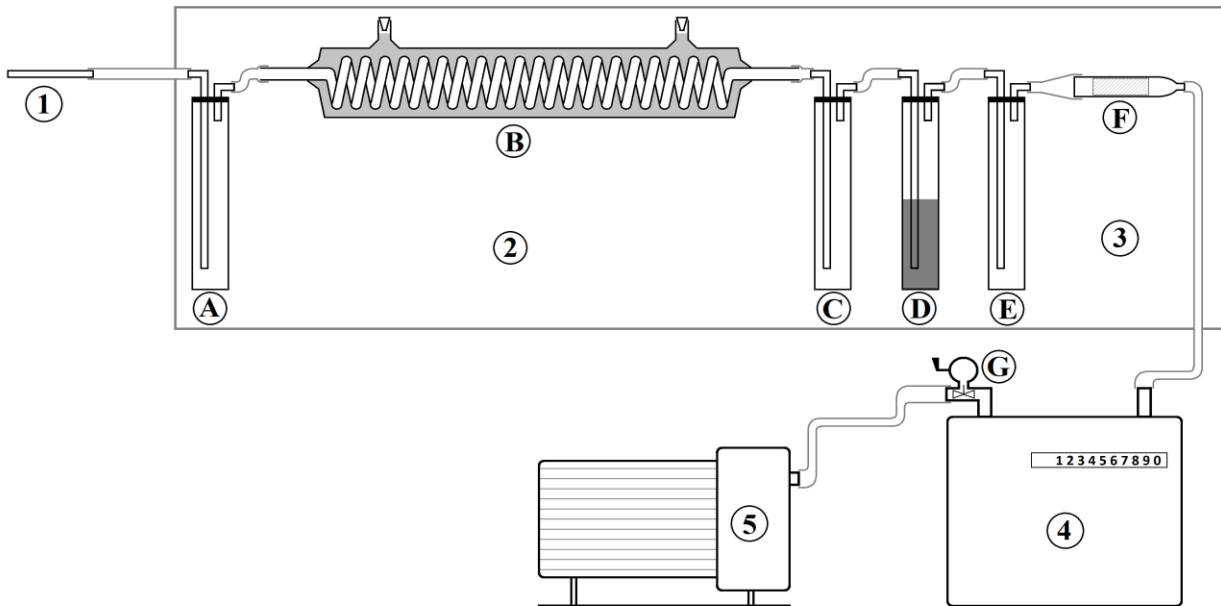

Teplota max: 500 °C
 Rychlost proudění: 1-70 dm³ min⁻¹



PŘEKRAČUJEME HRANICE
 PRZEKACZAMY GRANICE
 2014–2020



EVROPSKÁ UNIE / UNIA EUROPEJSKA
 EVROPSKÝ FOND PRO REGIONÁLNÍ ROZVOJ
 EUROPEJSKI FUNDUSZ ROZWOJU REGIONALNEGO



Stacionární odběrový bod

- Odběr PM_x
- Pomocí filtru VUKOPOR

	Filtr 0	Filtr 1	Filtr 2	Filtr 3	Filtr 4
SiC	-	95 %	80 %	80 %	98 %
Al₂O₃	1,5 %	-	18 %	15 %	1,8 %
MgO	-	2 %	1,5 %	2 %	-
CaO	0,5 %	2,5 %	-	-	-
SiO₂	98 %	0,5 %	0,5 %	0,5 %	0,2 %
CaCO₃	-	-	-	2,5 %	-

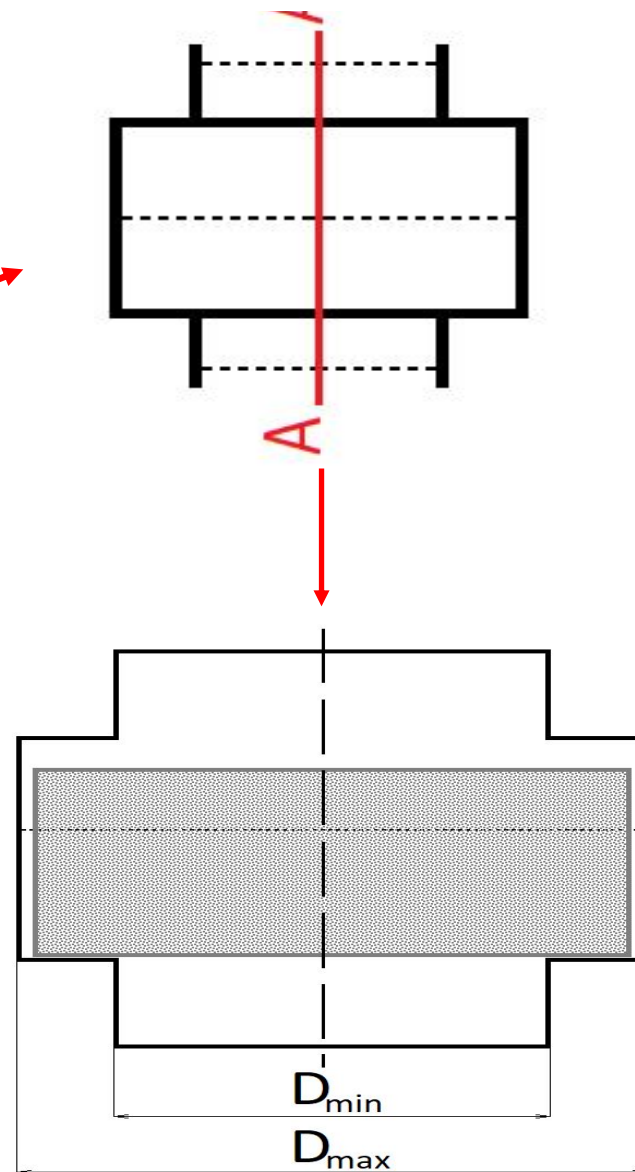
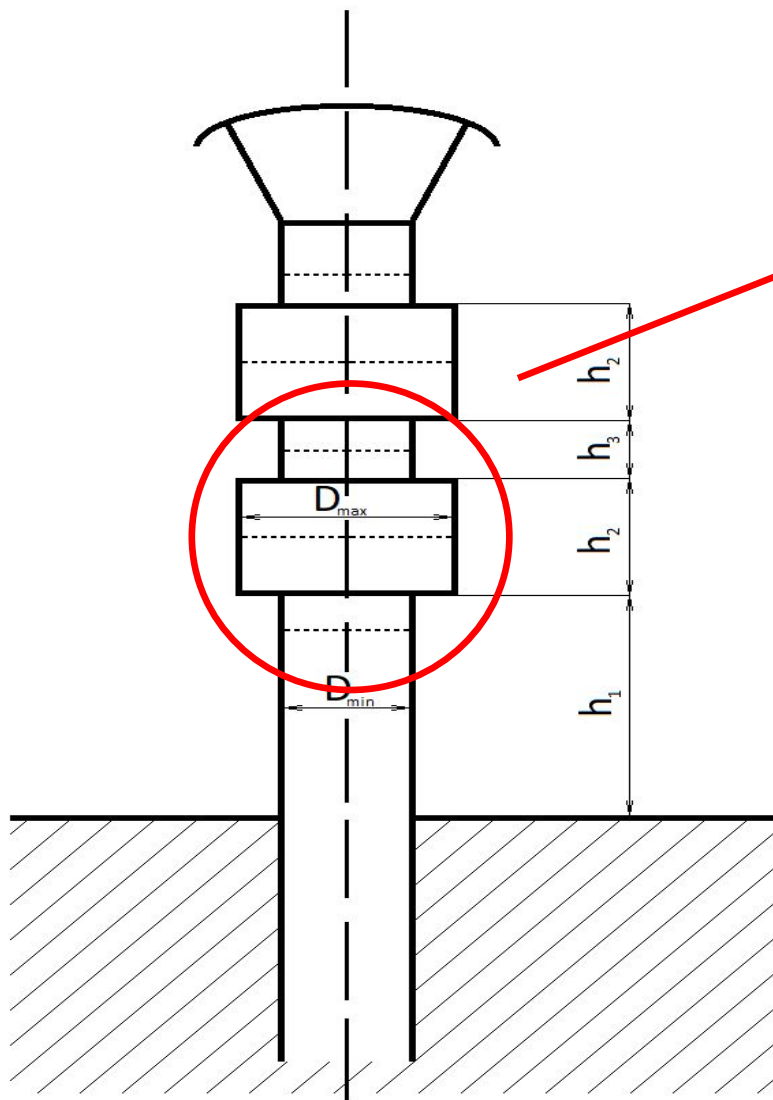



Parametry odběru

- Parametry odběr PAHs
 - Odběr 2 000 dm³
 - Délka odběru 3-5 h (jeden bod)
- Stacionární oděry
 - Doba odběru 24 h



Děkuji za pozornost